

PIPE BEVELING MACHINE MF3i

Video of application



Pipe beveling machine MF3i

Working range ID-OD: 40 - 168,3 mm

The MF3i is designed for the preparation of pipe ends, i.e. preparing of edges at individual pipe or membrane walls. It is used for steam bloc vessels to process pipe walls, to cut pipes or to chamfer welds. The machine can optionally be equipped with a compressed air an electric motor.



Dimensions

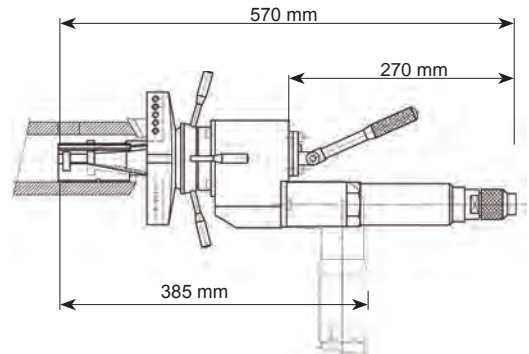
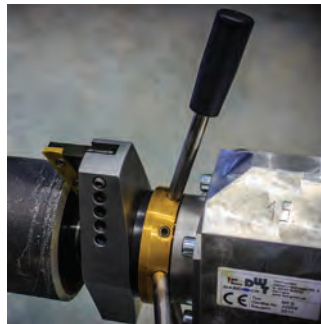

machine width: 89 mm

Specifications

Specifications MF3i			Pneumatic Motor		
Clamping range ID-ID	40 - 152 mm	1,574 - 5,984"	Power	850 W	1,2 HP
Working range ID-OD	40 - 168,3 mm	1,063 - 6,614"	Air pressure	6 bar	87 psi
Max. wall-thickness	25 mm	0,984"	Air consumption	0,96 m ³ /min	33,9 cfm
Feed	15 mm	0,591"	Air hose connection	1/4"	1/4"
Weight with electric motor	11,5 kg	25,3 lb	Features	speed control	
Weight with pneumatic motor	10,3 kg	22,7 lb	Electric Motor		
Weld prep	facing, V-prep, J-prep, counter boring		Power consumption	1.500 W (110V/230V)	2,0 HP
Materials	steel, stainless steel, duplex, high alloyed		Features restart and overload protection, speed adjustment, torque control		
Tooling	tool bits, TiN inserts, custom bits				
Machine body	Aluminium alloy				

Accessories & additional options



Tools for MF3i from page 48



Special tool for beveling elbows



Enlargement XL to cover range ID 25-152 mm (0,984- 5,984 inch)



Angle drive