

PIPE BEVELER MF3-R

Video of application



Pipe beveler MF3-R

Clamping range OD-OD: 12 - 44,5 mm

The MF3-R is used for the preparation of pipe ends, i.e. to cut edges of individual pipes or membrane walls. Because of its small dimension it is particularly suitable for the preparation inside membrane wall ports. The MF3-R can optionally be equipped with a pneumatic or an electric motor.



Dimensions

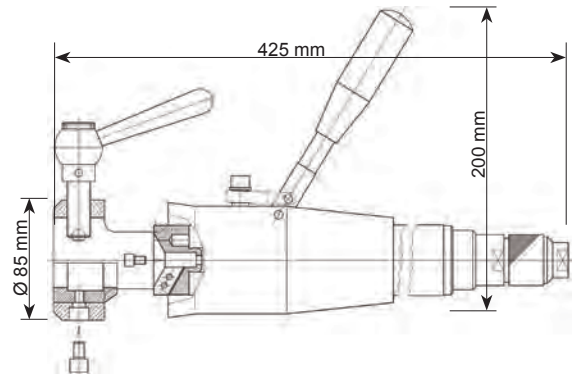

Specifications

Specifications MF3-R			Pneumatic Motor		
Working range ID-OD	9 - 44,5 mm	0,354 - 1,752"	Power	850 W	1,2 HP
Clamping range OD-OD	12 - 44,5 mm	0,472 - 1,752"	Air pressure	6 bar	87 psi
Max. wall-thickness	10 mm	0,393"	Air consumption	0,96 m ³ /min	33,9 cfm
Feed	15 mm	0,590"	Air hose connection	1/4"	1/4"
Weight with electric motor	6,0 kg	13,3 lb	Features	speed control	
Weight with pneumatic motor	4,8 kg	10,6 lb	Electric Motor		
Weld prep	facing, V-prep		Power consumption	1.200 W (110V/230V)	1,6 HP
Materials	steel, stainless steel, duplex, high alloyed		Features	restart and overload protection, speed adjustment, torque control	
Tooling	tool bits, TiN inserts, custom bits				
Machine body	Aluminium alloy				

Accessories & additional options



Tools for MF3-R
see from page 48