

ALO3 and ADR | Laser welding and brazing

CHARACTERISTICS

- Overlap fillet seam
- Overlap square-groove seam

DESCRIPTION OF FUNCTION

The combination of the ALO3 laser processing head and the integrated pressure wheel, ADR, facilitates flexible joining of overlap fillet seams. Laser welding or laser brazing processes are possible depending on the filler wire. Proven in applications across the globe, the integrated seam tracking facility of the ALO3 guides the laser processing head automatically and extremely reliably during the welding or brazing process.

No stick-slip effect occurs because the pressure wheel generates its pressure force electromotively. The integrated force sensor continuously regulates the actual pressure force. The required force is set precisely by the operator.

The ADR is controlled by the master machine, e.g. linear axis, via digital inputs/outputs. Extensive status signals keep the system operator informed at all times about the functional status of the ADR. To improve accessibility, for example, the ADR can be retracted by up to 30 mm.

ADVANTAGES

- Flexible, single-sided clamping device
- Removes the need for complicated and expensive fixed clamping fixtures
- High quality fillet seams thanks to reliable ALO3 seam tracking
- Force sensors ensure precise pressure force for light and heavy gauge metals
- No stick-slip effect
- High processing speeds up to approx. 8m / min with, for example, 4-kW laser output performance (application specific)

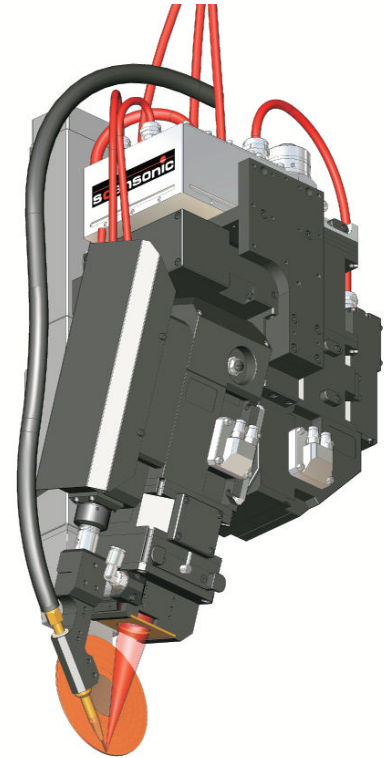

ADR attached to a ALO3