

# HUAHENG

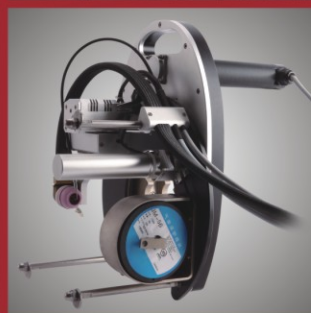

## ORBITAL Welding System

HUAHENG WELDING CO., LTD.

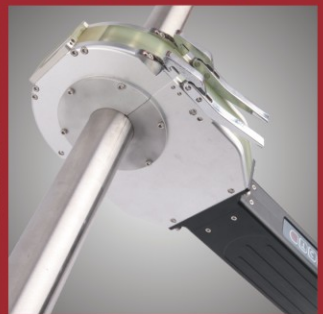
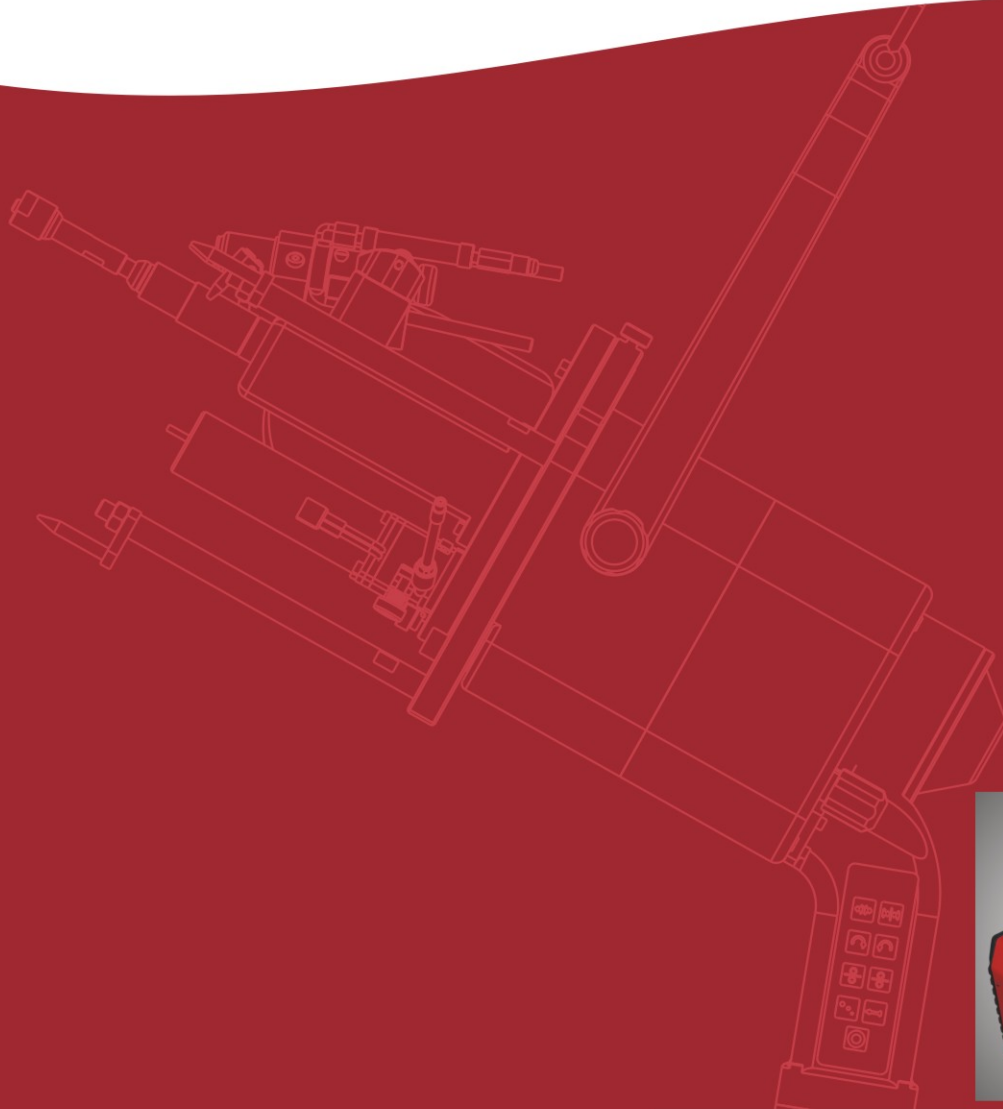

# TP040

## Tube to Tube-Sheet Welding Head

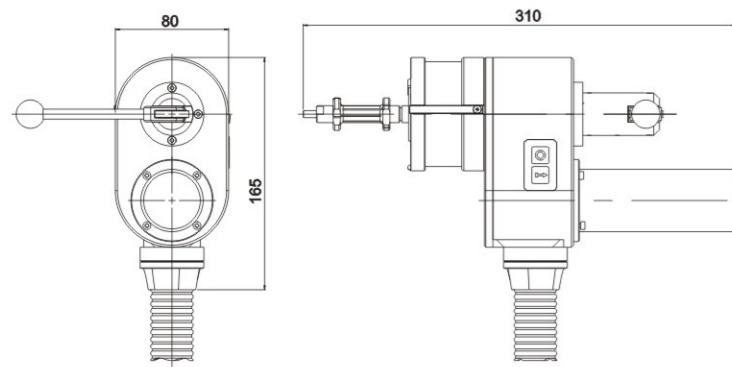

### Brief Introduction

This welding head is one special designed TIG welding head for tube to tube-sheet, which is used for carbon steel, stainless steel, mainly for flush tube connection without wire feeding.

Support equipment: i-Arc200 and i-Arc400 Programmable Orbital Welding Power Source.

Application: chemical, food, medicine, heat exchanger, power plant, military, nuclear and so on.



### Technical Specification

Material	Carbon steel, stainless steel, titanium alloy
Tube OD (mm)	Φ16—Φ38 (5/8"—1 1/2")
Connection	Flush tube
Tungsten OD (mm)	Φ2.4
Rotation Speed (rpm)	0.6~12
Welding angle	0°, 7°option. (standard 7°)
Protective gas	Ar
Cooling	Water
Cooling flow (ml/min)	≥600
Rate current	100A 60%
Weight (kg)	3.65 (no cable)
Dimension (mm)	310 × 80 × 165

### Features

- Widely used in power plant/condenser stainless steel/titanium alloy tube to tube-sheet welding;
- Without wire feeding, small size and light, easy for operation;
- Expandable collet positioning design, precise position;
- Closed welding achieving perfect welding quality;
- No wire winding, enhanced water cooling system, high duty cycle for long time using.

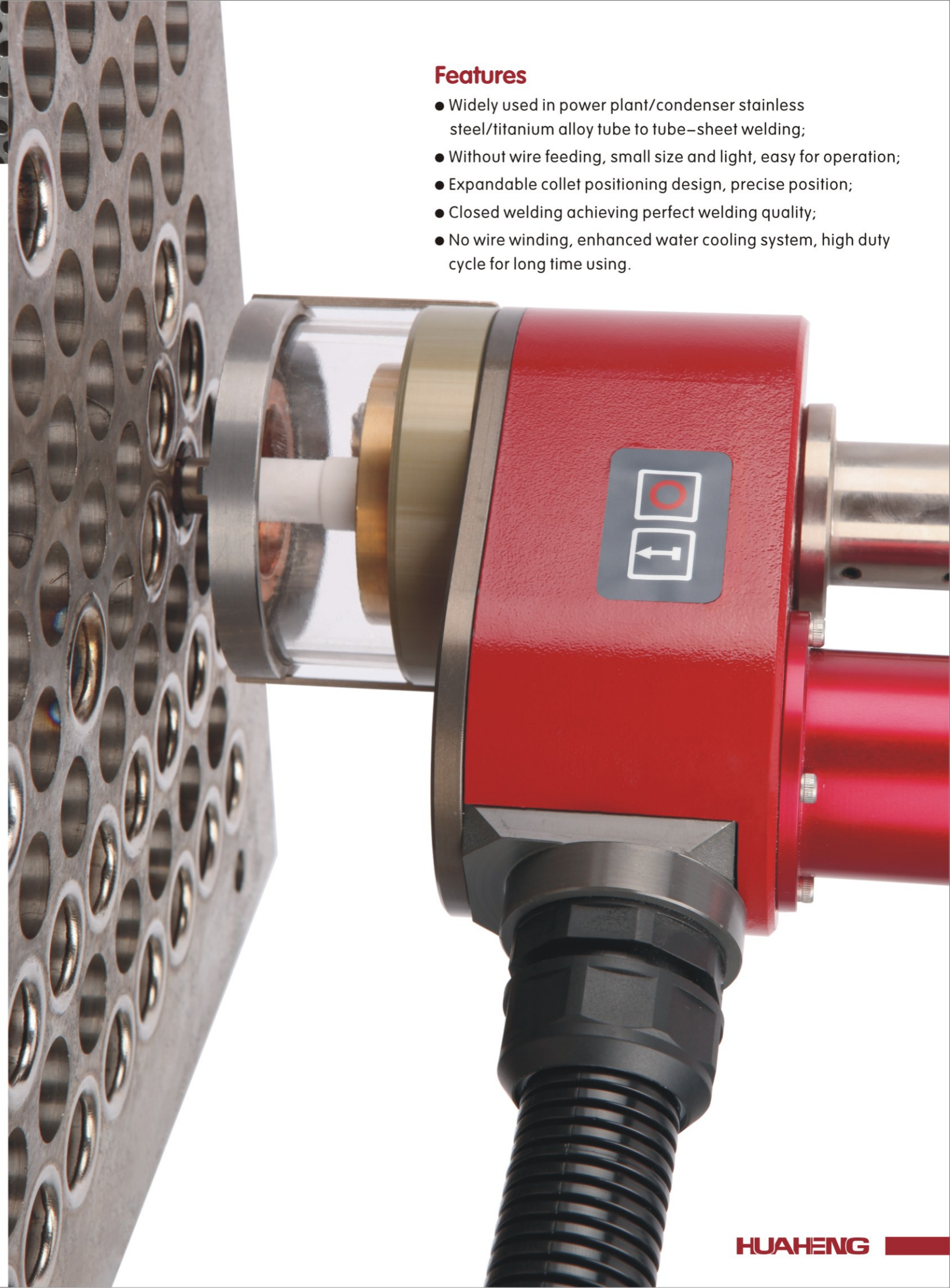

# HUAHENG

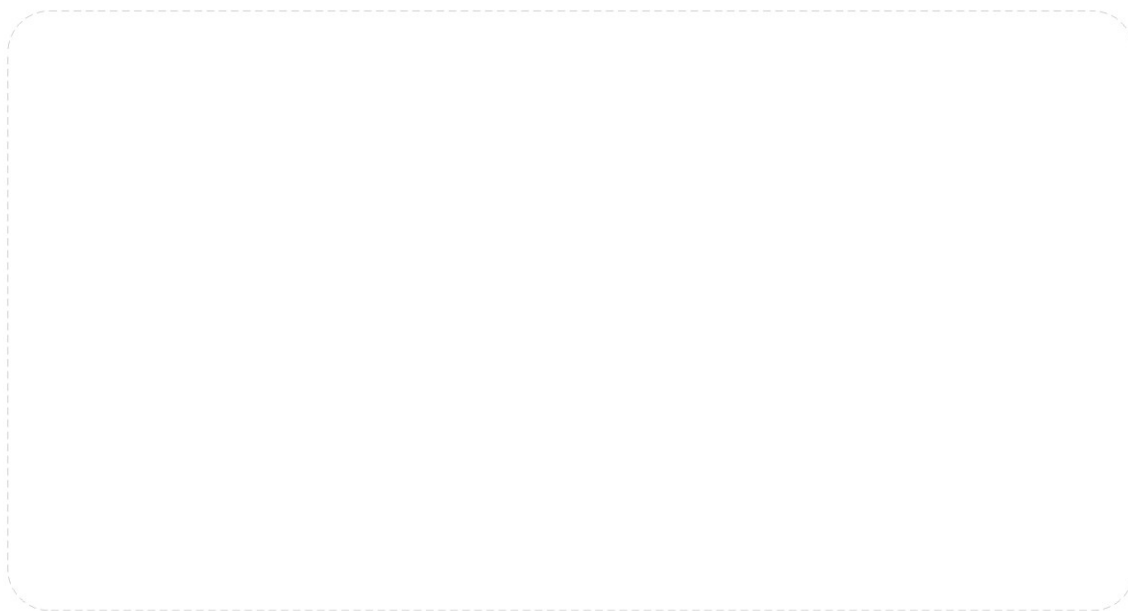

**HUAHENG**  
HUAHENG WELDING CO., LTD.

Add : No.1588 Boshi Road,Kunshan,Jiangsu,P.R.China. PC: 215347  
Tel : +86(0)512-81866666 Fax : +86(0)512-57328188  
[www.huahengweld.com](http://www.huahengweld.com) E-mail : [info@huahengweld.com](mailto:info@huahengweld.com)