

KUKA

**The shelf-mounted robot
for faster production**



KR 16-2 KS-S

»THE KUKA SHELF-MOUNTED ROBOTS: MASTERS OF PRECISION AND DEXTERITY

Greater flexibility and downward reach: KUKA shelf-mounted robots combine powerful motors and high-performance gear units with a very low base and an axis 2 that is located further forward. Options for installation on either the floor or a machine make these robots versatile, space-saving and particularly well suited to difficult removal processes.

And as if that were not enough, the robust design with low-wear components increases the service life and extends the maintenance intervals – thereby reducing your costs. For cleanrooms or environments with a high degree of fouling and high temperatures, the special variants Cleanroom (CR) and Foundry (F) are available for some of these models. **The advantages: high planning reliability and security of investment.**

»EXTREMELY FAST – EXTREMELY SPACE-OPTIMIZED

Increase your output: with the high-speed variant KR 16-2 KS-S. With greater drive power in the main axes, this model enables savings of up to 18% in cycle times for unloading tasks. Installation directly on the machine, the streamlined design of the robot wrist and minimal disruptive contours give this robot outstanding accessibility – even in confined spaces. **The advantages: greater flexibility and reduced space requirements.**

»EXTREMELY POWERFUL – EXTREMELY PRECISE

More speed and maximum output: the high installed motor capacity and high-torque gear units in all axes make the shelf-mounted robots highly dynamic and powerful. Added to this is the precision control, which gives the robots a repeatability of up to ± 0.05 mm. The result: better manufacturing quality, fewer rejects, and thus greater efficiency for your production. **The advantages: shorter cycle times and higher quality.**

»TECHNICAL DETAILS KR 16-2 KS-S

Dimensions: mm

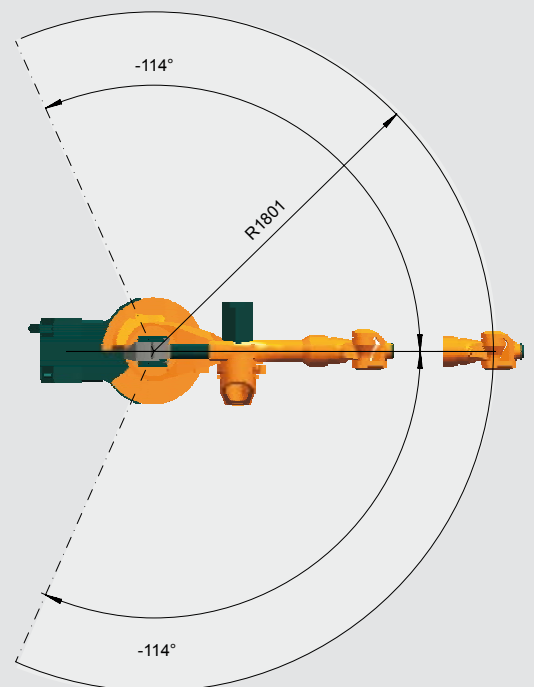
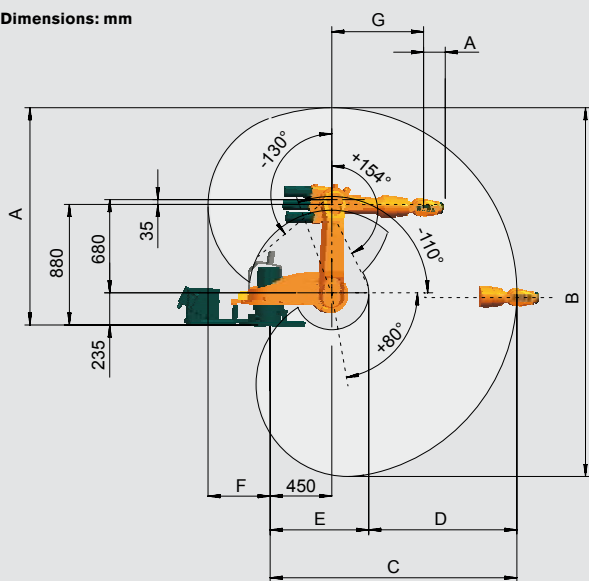

| Work envelope | Dimensions ¹⁾ | | | | | | | Volume |
|---------------|--------------------------|----------|----------|----------|--------|--------|--------|---------------------|
| | A | B | C | D | E | F | G | |
| KR 16-2 KS-S | 1,576 mm | 2,691 mm | 1,801 mm | 1,081 mm | 720 mm | 453 mm | 670 mm | 12.0 m ³ |

¹⁾ Relative to intersection of axes 4/5

» **EXTREMELY WELL-DESIGNED – EXTREMELY ERGONOMIC**

With the shelf-mounted robots, the name says it all: “KS” stands for “low base” and refers to the extremely low base frame. Together with axis 2 being located further forward, this shortens the lifting distances and gives the robots a longer downward reach. This makes them ideal for the efficient removal of castings or plastic parts. Mounted directly on the machine, they can reach faster and deeper into its workspace. **The advantages: improved process optimization and faster production.**

» **EXTREMELY VERSATILE – EXTREMELY SAFE**

KUKA offers you a comprehensive range of software. In addition to expandable system software and simulation programs for system design, we also provide you with specific application software, such as KUKA.PlastTech: the software coordinates and optimizes the work process of robots and injection molding machines – thereby reducing the cycle time for production of the parts. **The advantages: maximum ease of operation and major time savings.**



Having axis 2 located further forward offers high flexibility and outstanding accessibility, particularly when reaching downwards.



The streamlined design with low disruptive contours makes it possible to reach workpieces, even in confined spaces.

| Type | KR 16-2 KS-S |
|---|----------------------|
| Maximum reach | 1,801 mm |
| Rated payload | 16 kg |
| Suppl. load, arm/link arm/rotating col. | 10/variable/20 kg |
| Suppl. load, arm + link arm, max. | Variable |
| Maximum total load | 46 kg |
| Number of axes | 6 |
| Mounting position | Shelf-mounted, floor |
| Variant | Foundry |
| Positioning repeatability* | ±0.05 mm |
| Path repeatability* | |
| Controller | KR C2 edition2005 |
| Weight (excluding controller), approx. | 245 kg |
| Temperature during operation | +5 °C to +55 °C |
| Protection classification | IP 65 |
| Robot footprint | 500 x 500 mm |
| Connection | 7.3 kVA |
| Noise level | < 75 dB |

| Axis data | Range (software) | Speed with rated payload |
|-------------|------------------|--------------------------|
| | | 16 kg |
| Axis 1 (A1) | ±114° | 168°/s |
| Axis 2 (A2) | +80°/-110° | 173°/s |
| Axis 3 (A3) | +154°/-130° | 192°/s |
| Axis 4 (A4) | ±350° | 329°/s |
| Axis 5 (A5) | ±130° | 332°/s |
| Axis 6 (A6) | ±350° | 789°/s |

Drive system, electromechanical with brushless AC servomotors

*to ISO 9283

Details provided about the properties and usability of the products are purely for information purposes and do not constitute a guarantee of these characteristics. The extent of goods delivered and services performed is determined by the subject matter of the specific contract. No liability accepted for errors or omissions.



»THE KUKA ROBOT GROUP: YOUR STRONG PARTNER

Quality made in Germany, creativity and the utmost commitment to customers and business partners: these form the basis on which KUKA develops the best possible technologies and thus the optimal automation concepts. The result is that you receive custom-tailored solutions and benefit from decisive process optimization.

Genuine passion for the fascination of robotics is reflected in our slogan “KUKA YOUR IDEAS”, which is also our promise to you: Whatever you want to do, and however unusual your idea may be, with us you can implement anything – irrespective of the specific branch of industry and irrespective of whether or not a similar application has existed before.

Whatever task you give us, KUKA has the required specialists. In close cooperation with experienced system partners with competence in their respective industries, we do everything in our power to implement your ideas. Let us work on them together.

»KUKA SERVICES: ALWAYS THERE FOR YOU

You can rely on us to stand by you in every phase of a project: from planning and commissioning to maintenance and conversion. 24 hours a day. 365 days a year. The high-density KUKA service network ensures that we are always in your vicinity and can start your production in record time.

KUKA YOUR IDEAS

KUKA ROBOTER GMBH

Global Sales Center
Hery-Park 3000
86368 Gersthofen
Germany
Tel. +49 821 4533-0
Fax +49 821 4533-1616
info@kuka-roboter.de

Additional contact addresses:
www.kuka-robotics.com